UNIT 2
NC Machine Tooling

The cutting tools can be classified on the basis of setting up of tool, tool construction and cutting tool material:

On the Basis of Setting up of Cutting Tool

- (a) Preset tools.
- (b) Qualified tools.

On the Basis of Cutting Tool Construction

- (a) Solid tools.
- (b) Brazed tools.
- (c) Inserted bit tools.

On the Basis of Cutting Tool Material

- (a) High speed steel (HSS).
- (b) Cast alloy.
- (c) Cemented carbide.
- (d) Ceramics.
- (e) Boron Nitride.
- (f) Diamond.

1. On the Basis of Setting up of Cutting Tool

Preset Tools

The setting of tools in advance at a place away from the machine tool or offline, in special holders is known as preset tools. A presetting device is used to preset axial and radial positions of the tool tip on the tool holder. Once this is done, the tool holder is ready to be mounted on the machine and produce a known dimension.

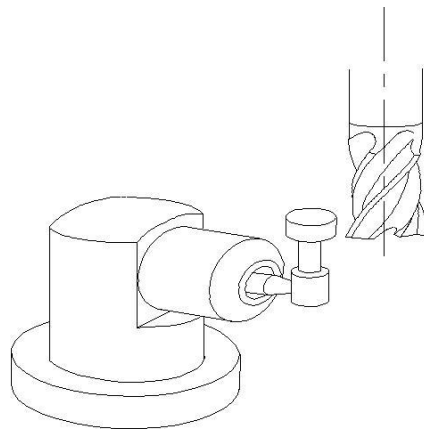

Figure: Tool Offset Determination in CNC Machines

Qualified Tools

Tool which fits into a location on the machine, where its cutting edge is accurately positioned within close limits relative to a specified datum on the tool holder or slide, is known as qualified tool. The cutting tools satisfy the following requirements :

- (a) Tools need not be measured individually.
- (b) No presetting device is used.
- (c) The dimensions of the tool holder which are fixed and known.
- (d) Set up time is reduced.
- (e) Control dimensions of the tool are nominal and fixed.
- (f) Higher control on resharpening e.g. drills, reamers.
- (g) Chip breaking facilities incorporated in tool.

The qualified tool with holder shown in Figure



Figure: Qualified Tooling for CNC Machines

2. On the Basis of Cutting Tool Construction

Solid Tools

Solid tools are usually made of High speed steel or High carbon steel. These tools are used on high speeds with sufficient quantity of cutting fluid to get good surface finish and longer tool life.



Figure : Solid Tool

Brazed Tools

A forged shank of high strength steel with belt of high speed steel, tungsten carbide stellite brazed to the shank on the cutting edge.

Inserted Bit Tools

The tools with inserts of harder and special grade carbide or ceramic materials. A wear resistant layer of Titanium nitride or Titanium carbide is coated on the insert it reduces the cost of tool. Inserts can be easily removed from the tool holder. So tool changing time and cost of machining are less.

3. On the Basis of Cutting Tool Material

High Speed Steel

The H.S.S. is carbon steel to which alloying elements like tungsten, chromium, vanadium, cobalt and molybdenum to be added to increase their hardness and wear resistance.

General use of HSS is 18-4-1.

18- Tungsten is used to increase hot hardness and stability.

4 – Chromium is used to increase strength.

1- Vanadium is used to maintain cutting edge.

In addition to these 2.5% to 10% cobalt is used to increase red hot hardness.

rest is iron.

- H.S.S is used for drills, milling cutters, single point cutting tools, dies, reamers etc.
- It loses hardness above 600°C.

Cast Alloys

This is a non ferrous alloy and gives high machining performance than that of H.S.Steel. Its hardness and toughness are high at higher temperatures.

It is an alloy of

Cobalt – 40 to 50%,

Chromium – 27 to 32%,

Tungsten – 14 to 29%,

Carbon – 2 to 4%

- It loses its hardness above 800°C
- It will give better tool life than H.S.S and can be used at slightly higher cutting speeds.
- They are weak in tension and like all cast materials tend to shatter when subjected to shock load or when not properly supported

Cemented Carbides

It contains 5% carbon, 13% cobalt and 81% tungsten. This tool is widely used in modern costly machines as tip tools. The tool setting time is reduced.

- Produced by powder metallurgy technique.
- Speed can be used 6 to 8 times that of H.S.S.

- Can withstand up to 1000°C.
- High compressive strength
- They are very stiff and their young's modulus is about 3 times that of the steel.
- High wear resistance.

Ceramics

It can be used for higher cutting speed, superior surface finish and greater machining flexibility. The Aluminium oxides, boron carbides, silicon carbide, titanium borides and titanium carbides are known as ceramics.

Cubic Boron Nitride

- (a) High wear resistance.
- (b) Used for machining hardened steel and high temperature alloys.

Diamond

- (a) Low friction and high wear resistance.
- (b) Good cutting edge.

DESIGN FEATURES OF CNC TOOLING

In general the following points are to be considered while designing of CNC tooling :

- (a) To give High accuracy.
 - (b) For variety of operations.
 - (c) Interchangeability to produce same accuracy.
 - (d) Flexibility.
 - (e) Rigidity of tooling to withstand cutting forces.
 - (f) Rigidity to transmit the power at higher speeds.
 - (g) Quick changing of tools to keep the idle time minimum.
-